



GIEBEL Adsorber®

CONTENT

OVERVIEW

Application areas	02
Adsorber series	03
Accessories	07
Services	08

MAIN APPLICATIONS

Hydraulic power packs	09
Gears	11
Storage tanks	13
Barrels & IBC	15
Transformers	17
Mobile machinery	19
Pipelines (Inline)	21

MORE PRIVATE LABELS

GIEBEL Xdry®	23
GIEBEL Sense®	25
GIEBEL Refresh®	27

COMPANY

Development & Production	28
GIEBEL worldwide	29

Want to find out more about GIEBEL? Then it's worth taking a look at our website www.giebel-adsorber.com

SAVE MONEY BY **PREVENTING CONDENSATION** IN HYDRAULICS, GEARBOXES, BARRELS, IBCS, STORAGE TANKS, TRANSFORMERS AND MORE.

Oil in hydraulic units, gearboxes and transformers expands during operation due to heat generation and contracts again as soon as the system comes to a standstill and cools down. To compensate the differential pressure, air is either forced out of the system or sucked in.

If this air is not filtered, moisture easily enters the system. It condenses inside and drops into hydraulic or transmission oil. Condensation damage to the tank and contamination of the oil are common consequences. The same occurs in storage tanks, barrels and IBC containers when air flows in during emptying to equalize pressure.

With the installation of a GIEBEL Adsorber®, air is dried before it enters a system. Valves on the bottom ensure that the application can be properly ventilated.

A variety of connections as well as an extensive range of accessories ensure that GIEBEL Adsorbers® can also be adapted for systems that are difficult to access and those that are operated in particularly harsh environments (e.g. offshore).



Heinrich Laas

Managing Director
GIEBEL FilTec GmbH

ADSORBERS PREVENT MOISTURE FROM ENTERING A SYSTEM AND OIL MIST / POLLUTANTS FROM ESCAPING.



HYDRAULIC POWER PACKS

By drying the incoming air, adsorbers protect hydraulic units from condensation damage.



GEARS

Sucked-in, moist ambient air significantly reduces the service life of a gear oil. Adsorbers can prevent the ingress of moisture.



STORAGE TANKS

When tanks cool down, humid air leads to condensate and thus reduces the quality of the substance in the tank. GIEBEL has developed special tank aeration dryers to keep the air dry.



BARRELS & IBC

Aeration dryers from GIEBEL can be used to protect hygroscopic substances such as isocyanate, oils and biological fuels.



TRANSFORMERS

GIEBEL dehumidifiers protect transformers from hydrolysis of the cellulose paper and thus from a reduction in the degree of polymerization by effectively drying and filtering the moist supply air.



MOBILE MACHINERY

Adsorbers protect hydraulics of mobile machines that are exposed to high temperature fluctuations or are operated with particularly moisture-sensitive bio-oils against the ingress of moisture.



PIPELINES (INLINE)

GIEBEL inline adsorbers are mounted directly in a pipe to dry the air or to filter out pollutants. They can be filled with silica gel, molecular sieve or activated carbon.

CUSTOMIZED SOLUTIONS

Whether adsorbers for drying the supply air, separating oil mist and pollutants or preventing the entry of liquid water, we develop filters that are up to any challenge. With a wide range of connections and accessories, as well as disposable and refillable cartridges, we adapt our adsorbers to your systems and operating conditions. Different sizes with up to 150kg of desiccant even make it possible to adsorb large quantities.



ADSORBER SERIES.

An Overview.

**Dehumidifier /
Ventilation dryer**
for the separation of
humidity

Water separator
for the separation of
liquid water

**Oil mist separator /
Aerosol filter** for the
separation of oil mist
& pollutants

Gas separator
for the separation
of gases



VV-D series

GIEBEL Adsorbers® of the VV-D series are disposable aeration dryers without valves. They are suitable for indoor, outdoor and offshore use on hydraulic power packs, gearboxes, drums and IBCs as well as on mobile machinery.

The plastic housing is filled with GIEBEL Xdry®. The desiccant mixture ensures effective drying of the supply air. A 3µm filter additionally cleans the sucked-in air. When air is forced out of the system, a layer of activated carbon adsorbs escaping oil mist, thus protecting the desiccant and the environment from contamination. When the adsorber is saturated, it is replaced. We recommend the use of the VV-D series especially for plants with permanent air exchange and short maintenance intervals.



VV-DV series

GIEBEL Adsorbers® of the VV-DV series are aeration dryers with a one-way cartridge and a valve part. They are suitable for indoor, outdoor and offshore use on hydraulic power packs, gearboxes, storage tanks and mobile machinery.

The plastic housing is filled with GIEBEL Xdry®. The desiccant mixture ensures effective drying of the supply air. A 3µm filter additionally cleans the sucked-in air. When air is forced out of the system, a layer of activated carbon adsorbs escaping oil mist, thus protecting the desiccant and the environment from contamination. When the adsorber is saturated, only the cartridge is replaced. The stable and frost-proof valve part remains on the system. It protects the adsorber from unnecessary loading, enables use under extreme, dusty ambient conditions, and ensures minimal pressure build-up even at high air flows.



VV-R series

GIEBEL Adsorbers® of the VV-R series are multi-way aeration dryers without valves. They are suitable for indoor and outdoor use on hydraulic power packs, gearboxes, drums and IBCs as well as on mobile machinery.

The plastic housing is filled with GIEBEL Xdry®. The desiccant mixture ensures effective drying of the supply air. A 3µm filter additionally cleans the sucked-in air. When air is forced out of the system, a layer of activated carbon adsorbs escaping oil mist, thus protecting the desiccant and the environment from contamination. When the adsorber is saturated, desiccant and all other components of the internal system can be replaced at low cost. We recommend the use of the VV-R series especially for plants with constant air exchange and short downtimes.

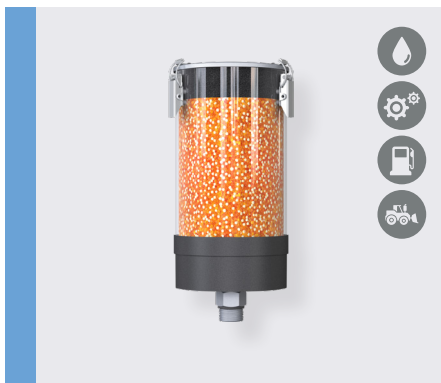

VV-RV series

GIEBEL Adsorbers® of the VV-RV series are aeration dryers with a reusable cartridge and a valve section. They are suitable for indoor and outdoor use on hydraulic power packs, gearboxes, storage tanks and mobile machinery.

The plastic housing is filled with GIEBEL Xdry®. The desiccant mixture ensures effective drying of the supply air. A 3µm filter additionally cleans the sucked-in air. When air is forced out of the system, a layer of activated carbon adsorbs escaping oil mist, thus protecting the desiccant and the environment from contamination. When the adsorber is saturated, desiccant and all other components of the internal system can be replaced at low cost. The stable valve section protects the adsorber from unnecessary loading, enables it to be used in extreme, dusty ambient conditions, and ensures minimal pressure build-up even at high air flows.

MA-R series

GIEBEL Adsorbers® of the MA-R series are multi-way aeration dryers without valves. They are suitable for indoor and outdoor use on barrels and IBCs. The all-aluminum housing is filled with GIEBEL Xdry®. The desiccant mixture ensures effective drying of the supply air. A 3µm filter additionally cleans the sucked-in air. When air is forced out of the system, a layer of activated carbon adsorbs escaping oil mist and other pollutants, thus protecting the desiccant and the environment from contamination. When the adsorber is saturated, desiccant and all other components of the internal system can be replaced at low cost. MA-R adsorbers can also be used when isocyanates, polyols, DOT4, SKYDROL, solvents or oils need to be protected from moisture ingress. They are available with FKM or EPDM seals and can be used in zone II 2 G / D IIC T4 according to the ATEX product directive 2014/34/EU.



MA-RV series

GIEBEL Adsorbers® of the MA-RV series are multi-way aeration dryers with valves. They are suitable for indoor and outdoor use on hydraulic power packs, gearboxes, storage tanks and mobile machinery. The all-aluminum housing is filled with GIEBEL Xdry®. The desiccant mixture ensures effective drying of the supply air. A 3µm filter additionally cleans the sucked-in air. When air is forced out of the system, a layer of activated carbon adsorbs escaping oil mist, thus protecting the desiccant and the environment from contamination. When the adsorber is saturated, desiccant and all other components of the internal system can be replaced at low cost. MA-RV adsorbers are used for aeration of aggressive materials as well as in harsh environments. The aeration dryers are available with FKM or EPDM seals and can be used in zone II 2 G / D IIC T4 according to the ATEX product directive 2014/34/EU.



ME-RV series

GIEBEL Adsorbers® of the ME-RV series are multi-way aeration dryers with valves. They are suitable for indoor, outdoor and offshore use on hydraulic power packs, gearboxes, storage tanks and mobile machinery. The stainless steel housing is filled with GIEBEL Xdry®. The desiccant mixture ensures effective drying of the supply air. A 3µm filter additionally cleans the sucked-in air. When air is forced out of the system, a layer of activated carbon adsorbs escaping oil mist, thus protecting the desiccant and the environment from contamination. When the adsorber is saturated, desiccant and all other components of the internal system can be replaced at low cost. ME-RV adsorbers are used for the ventilation of offshore plants as well as in the chemical industry or for the ventilation of large storage tanks. The adsorbers are available with FKM or EPDM seals and can be used in zone II 2 G / D IIC T4 according to the ATEX product directive 2014/34/EU.



MS-R series

GIEBEL Adsorbers® of the MS-R series are multi-way aeration dryers without valves. They are suitable for indoor, outdoor and offshore use on storage tanks. The stainless steel housing is filled with GIEBEL Xdry®. The desiccant mixture ensures effective drying of the supply air. When the adsorber is saturated, desiccant and all other components of the inner workings can be replaced at low cost. MS-R adsorbers are used to ventilate large storage tanks of more than 60cbm. The adsorbers can be used in zone II 2 G / D IIC T4 according to the ATEX product directive 2014/34/EU and meet the criteria of corrosivity category CX. In combination with a venting system and a supply air valve, the air flow into and out of a tank can be controlled.



VG-D series

GIEBEL Adsorbers® of the VG-D series are disposable oil mist separators without valves. They are suitable for indoor and outdoor use on hydraulic power packs, gearboxes, barrels & IBC. The plastic housing is filled with activated carbon. Combined with a slosh protection and oil demister, the activated carbon cleans the air coming out of the unit, protecting the environment from oil aerosol contamination. When the adsorber is saturated (discoloration of the white silica gel layer), it is replaced. VG-D adsorbers are used on turbo gearboxes, test benches and recirculating oil lubrication systems.

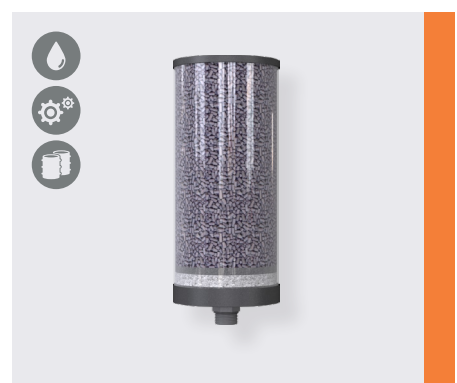



VG-R series

GIEBEL Adsorbers® of the VG-R series are multi-way oil mist separators without valves. They are suitable for indoor and outdoor use on hydraulic power packs, gearboxes, barrels & IBC. The plastic housing is filled with activated carbon. Combined with a slosh protection and oil demister, the activated carbon cleans the air coming out of the unit, protecting the environment from oil aerosol contamination. When the adsorber is saturated (discoloration of the white silica gel layer), both the activated carbon bed and all other components of the internal system can be replaced at low cost. VG-R adsorbers are used on turbo gearboxes, test benches and recirculating oil lubrication systems.



TB-DV series

GIEBEL Adsorbers® of the TB-DV series are disposable dehumidifiers especially for transformers. They are suitable for indoor and outdoor use. The plastic housing is filled with GIEBEL Xdry®. The desiccant mixture ensures effective drying of the supply air. In addition, the dehumidifiers have a stable valve part made of fiberglass-reinforced polyamide and an oil reservoir. When the adsorber is saturated, the cartridge can be unscrewed and replaced at low cost as part of our GIEBEL Refresh® system. The suspended version is available with all common connections for transformers. The series has an activated carbon layer to separate escaping oil mist. This ensures cyclic self-regeneration and thus very long maintenance intervals.



TB-RV series

GIEBEL Adsorbers® of the TB-RV series are reusable dehumidifiers especially for transformers. They are suitable for indoor and outdoor use. The plastic housing is filled with GIEBEL Xdry®. The desiccant mixture ensures effective drying of the supply air. In addition, the dehumidifiers have a stable valve part made of fiberglass-reinforced polyamide and an oil reservoir. When the adsorber is saturated, both desiccant and all other internal components can be replaced at low cost. The suspended version is available with all common connections for transformers. The series has an activated carbon layer to separate escaping oil mist. This ensures cyclic self-regeneration and thus very long maintenance intervals.

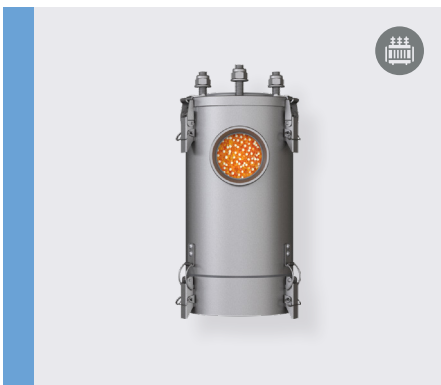

TM-RV series

GIEBEL Adsorbers® of the TM-RV series are reusable dehumidifiers especially for transformers. They are suitable for indoor, outdoor and offshore use. The stainless steel housing is filled with GIEBEL Xdry®. The desiccant mixture ensures effective drying of the supply air. In addition, the dehumidifiers have a stable valve part and an oil reservoir. When the adsorber is saturated, both desiccant and all other internal components can be replaced at low cost. The suspended version is available with all common connections for transformers. The series features an activated carbon layer to separate escaping oil mist. This ensures cyclic self-regeneration and thus very long maintenance intervals. The adsorbers can be used in zone II 2 G / D IIC T4 according to the ATEX product directive 2014/34/EU and meet the criteria of corrosivity category CX.

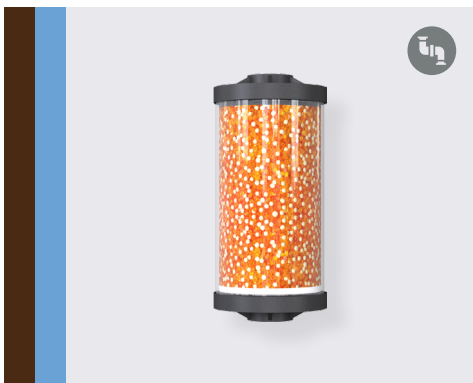

VL-D series

GIEBEL Adsorbers® of the VL-D series are disposable inline filters with connections on both sides for installation in a line. The plastic housing is filled with GIEBEL Xdry®. The desiccant mixture ensures effective drying of the supply air. In addition, a filter is integrated to separate abrasion and ambient dirt. VL-D adsorbers are used to dry air streams in electronic, optical or other systems. If required, the inline filters can also be filled with other desiccants - e.g. molecular sieves (3A, 4A, 5A, 13X), if other substances are to be adsorbed specifically in addition to the separation of moisture.

VL-R series

GIEBEL Adsorber® of the VL-R series are reusable inline filters with threaded connections on both sides. The plastic housing is filled with GIEBEL Xdry®. The desiccant mixture ensures effective drying of the supply air. In addition to the desiccant, a filter is integrated that separates abrasion and ambient dirt.

VL-R adsorbers are used for drying air flows in small laser systems through to large storage tanks. With a DN50 thread, even large volume flows can be fed through the adsorber.

If required, the inline filters can also be filled with other desiccants - e.g. with molecular sieves (3A, 4A, 5A, 13X) if other substances are to be adsorbed in addition to the separation of moisture. Once the adsorber is saturated, both the desiccant filling and all other components of the inner workings can be replaced at low cost.



VM-R series

GIEBEL Adsorbers® of the VM-R series are reusable inline filters for use under extremely harsh conditions or in explosion protection zones according to ATEX 2014. Consisting of a metal housing with threaded connections on both sides, these adsorbers can be installed in pipelines and ensure that moisture is separated and the system to be ventilated is protected.

If required, the inline filters can also be filled with other desiccants - e.g. molecular sieves (3A, 4A, 5A, 13X), if other substances are to be specifically adsorbed in addition to the separation of moisture. Once the adsorber is saturated, the desiccant bed and all other components of the inner workings can be replaced at low cost.



HS-D series

GIEBEL Adsorbers® of the HS-D series protect gearboxes from water droplet ingress while allowing them to breathe. With the help of an ePTFE filter in the core of the robust polyamide housing, the gear oil is protected from contamination with water, even when the gear is used outdoors or cleaned with water.

The 0.3µm pores of the membrane filter retain water or oil, but allow air to flow through. The pressure build-up remains low.

The HS-D membrane filters are an excellent alternative to adsorbers when liquid water is a challenge for a gearbox, but humidity does not cause problems.



ACCESSORIES.

For mounting, monitoring, protecting and venting.

MOUNTING

Tight spaces, systems that are difficult to access & very special connection requirements - with GIEBEL accessories, we already provide a wide range of solutions to meet the installation challenges of different system types.

We also develop individual solutions - perfectly tailored to your operating conditions.

MONITORING

With the GIEBEL Sense® sensor program, we make the maintenance of your adsorbers child's play. Whether analog or via Modbus RTU - the sensors provide information about loading statuses and upcoming maintenance.

PROTECTING

Suitable accessories to protect your adsorbers under harsh operating conditions as well as to protect your systems against overpressure/underpressure or swell and against oil mist escaping into the environment make your systems safe.

VENTING

Venting systems that allow air to flow in or out unhindered when filling and emptying tanks without vapor recovery, in combination with adsorbers, ensure that the stored substances remain protected from moisture and corrosion on tank systems is avoided.



Flange adapters

for mounting on hydraulic tanks



Sensors

for monitoring the adsorber loading



IBC-Covers

for mounting on IBC containers



Suction lances

for connecting barrel pumps and bypass filter systems to a hydraulic tank and for easy removal of substances from the bottom



Filling adapters

for easy refilling of oil into a hydraulic power unit or gearbox



Oil separators

for plants with high oil mist emission, to protect adsorbers from contamination by larger oil particles



Wall mounts
for the flexible installation of adsorbers



Valve adapters
for mounting adsorbers on mobile machines with tank preload of 0.3 and 0.5bar

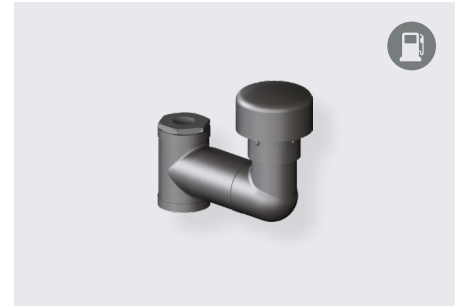

Ventilation systems
for filling a tank without vapor recovery



Mounting adapters
for mounting on horizontal barrels and in confined spaces



Protection adapter
to output an optical or electronic signal when the vacuum is too high



Protection hoods
for protection in harsh environments, e.g. in mines or offshore operations



Sleeves & Reductions
for flexible mounting

SERVICES.



Branding
Adsorbers adapted to your corporate design with your own label sticker and in matching color.



GIEBEL Refresh®
Sustainability is important to us. That's why we take back used adsorbers and reuse long-lasting components.



Inspection
Not sure if your adsorber is working properly? We check it.

ADSORBERS FOR **HYDRAULIC POWER UNITS.**

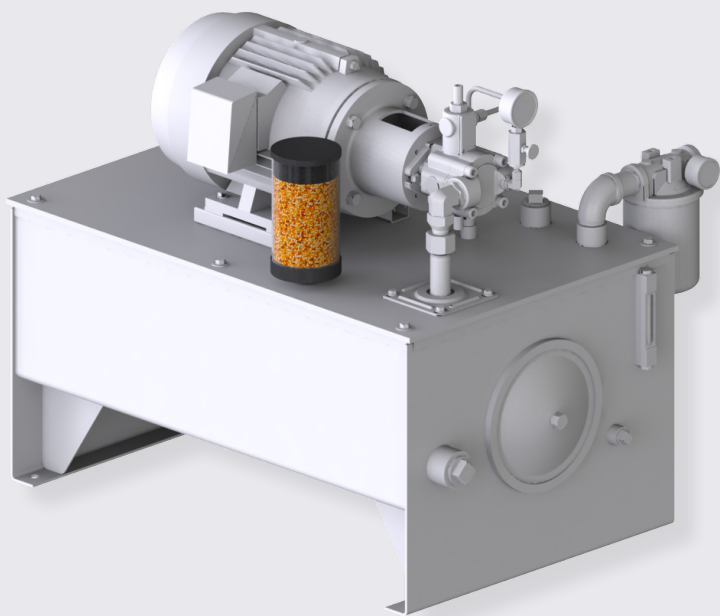

GIEBEL offers a wide range of adsorbers specially designed for **hydraulic power packs**. They are available with and without valves, with FKM or EPDM seals, according to ATEX 2014, for indoor, outdoor and offshore use, and as disposable or refillable versions. They are divided into adsorbers for air drying and adsorbers for separation of pollutants.

The adsorber size is determined on the basis of the tank or shuttle volume.

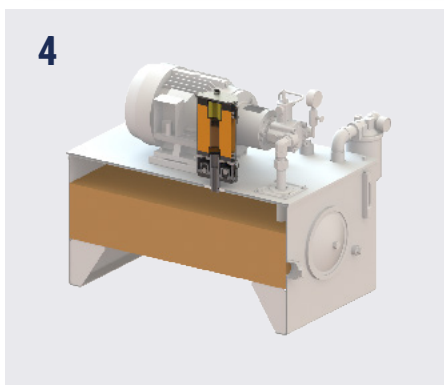
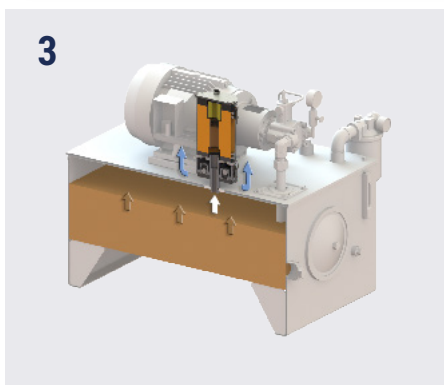
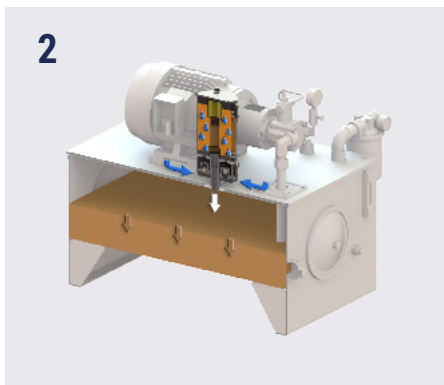
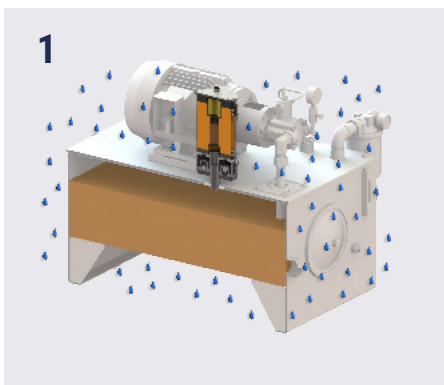

HOW ADSORBERS WORK ON HYDRAULIC POWER PACKS

1 The adsorber is mounted on the hydraulic power unit. The ambient air is enriched with moisture.

2 Hydraulic oil is removed from the tank, the oil level drops and pressure is equalized by incoming air. The adsorber separates moisture up to 2% RH (10% RH on average).

3 When the hydraulic oil is pumped back into the tank, the oil level rises and the pressure is equalized by escaping dry air.

4 Because the air inside the system always remains dry, no condensation takes place in the hydraulic unit even if the ambient air drops below the dew point.

ADSORBERS FOR USE ON **HYDRAULIC UNITS.**



Disposable version without valves, with FKM seal, for indoor, outdoor & offshore use



Disposable version with valves, with FKM seal, for indoor, outdoor & offshore use



Reusable version without valves, with FKM seal, for indoor & outdoor use



Reusable version with valves and FKM seal, for indoor & outdoor use



Reusable version with valves and FKM / EPDM seal, for indoor & outdoor use according to ATEX



Reusable version with valves and FKM / EPDM seal, for indoor, outdoor & offshore use according to ATEX



Disposable version without valves, with FKM seal, for indoor & outdoor use



Reusable version without valves, with FKM seal, for indoor & outdoor use



Tank- / shuttle volume	Adsorber size aeration dryer	Adsorber size oil mist separator
0-50l	1L	1L
51-100l	2L	2L
101-400l	3M	3L
401-800l	3L	5L
801-1,800l	5M	5XL
1,801-3,600l	5L	
3,601-5,400l (up to 210l/min - max. 1250l/min)	5XL	

ADSORBERS FOR **GEARS**.

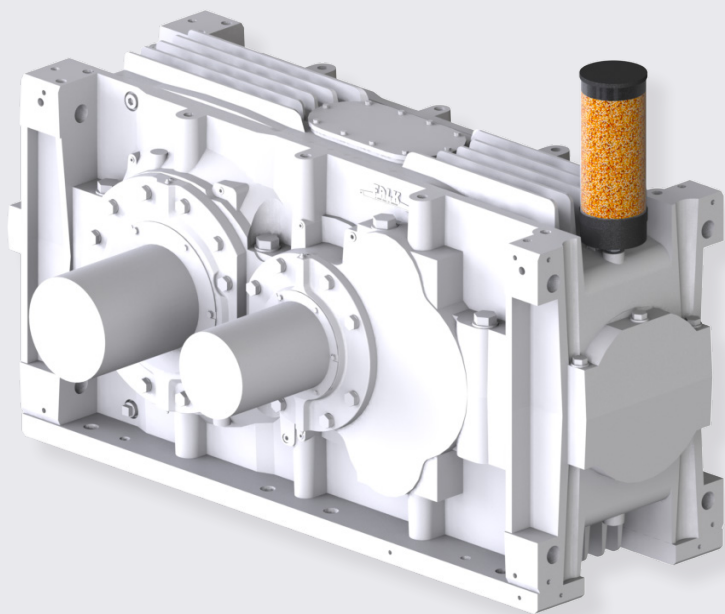

GIEBEL offers a wide range of adsorbers specially designed for **gears**. They are available with and without valves, according to ATEX 2014, for indoor, outdoor and offshore use, and as disposable or refillable versions. They are divided into adsorbers for air drying and adsorbers for separation of pollutants.

The adsorber size is determined based on the air & oil volume.

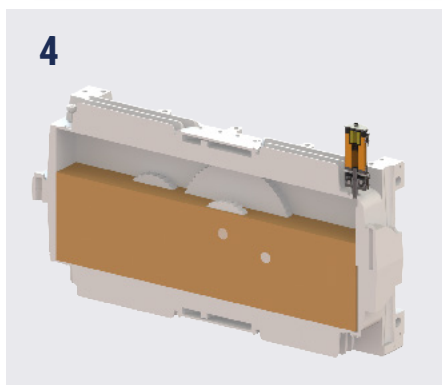
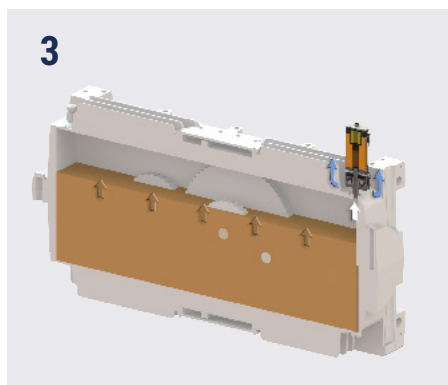
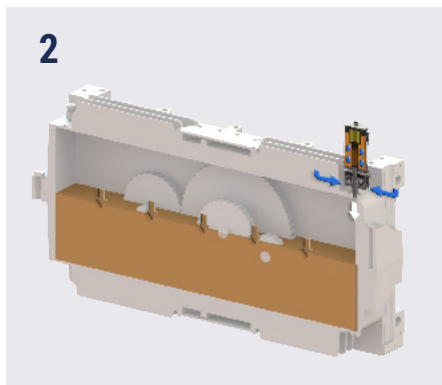
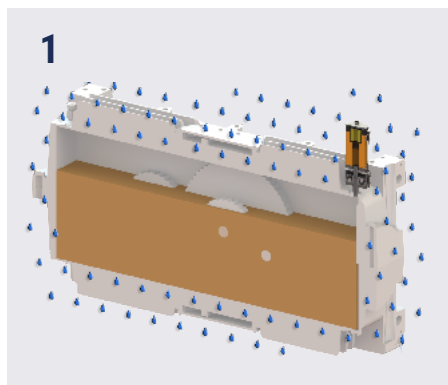

HOW ADSORBERS WORK ON GEARS

1 The adsorber is mounted on the gear. The ambient air is enriched with moisture.

2 If the gear cools down, the oil level drops and the pressure is equalized by incoming air. The adsorber separates moisture up to 2% RH (10% RH on average).

3 When the gearbox warms up, the oil level rises and the pressure is equalized by escaping dry air.

4 Because the air inside the system always remains dry, no condensation takes place in the gear even if the ambient air drops below the dew point.

ADSORBERS FOR USE ON **GEARS**.



VV-D

Disposable version without valves, with FKM seal, for indoor, outdoor & offshore use



VV-DV

Disposable version with valves, with FKM seal, for indoor, outdoor & offshore use



VV-R

Reusable version without valves, with FKM seal, for indoor & outdoor use



VV-RV

Reusable version with valves and FKM seal, for indoor & outdoor use



MA-RV

Reusable version with valves and FKM / EPDM seal, for indoor & outdoor use according to ATEX



ME-RV

Reusable version with valves and FKM / EPDM seal, for indoor, outdoor & offshore use according to ATEX



Disposable version without valves, with FKM seal, for indoor & outdoor use



Reusable version without valves, with FKM seal, for indoor & outdoor use



Disposable version with ePTFE filter (water-repellent)



Available with a wide range of connections

BSP, NPT, Metric, Slipfit

Air & Oilvolume	Adsorber size aeration dryer	Adsorber size oil mist separator	Adsorber size water separator
0-10l	1L	1L	S
11-100l	2M	2L	M
101-400l	2L	3L	
401-1,200l	3M	5L	
1,201-2,400l	3L	5XL	
2,400-...l	5M		

ADSORBERS FOR **STORAGE TANKS.**

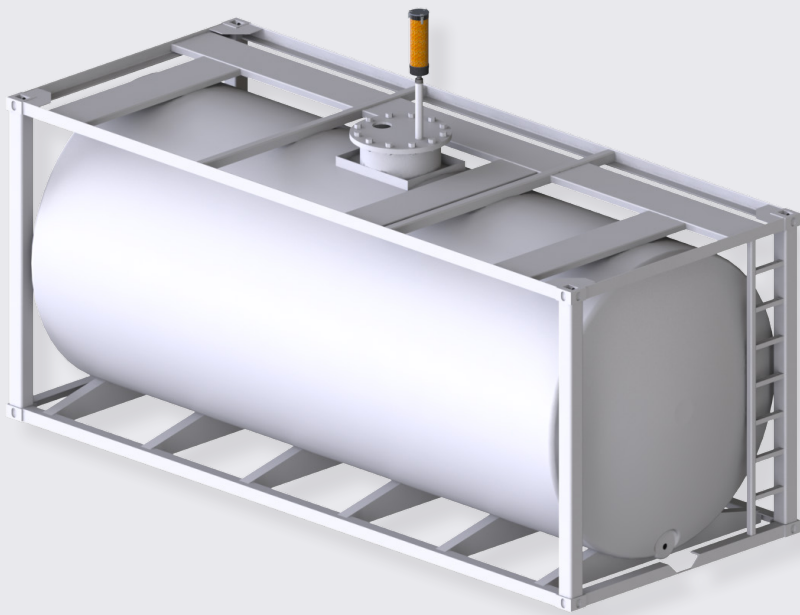

GIEBEL offers a wide range of adsorbers specially designed for **storage tanks**. They are available with and without valves, with FKM or EPDM seals, according to ATEX 2014, for indoor, outdoor and off-shore use, and as disposable or refillable versions.

The adsorber size is determined on the basis of the tank volume.

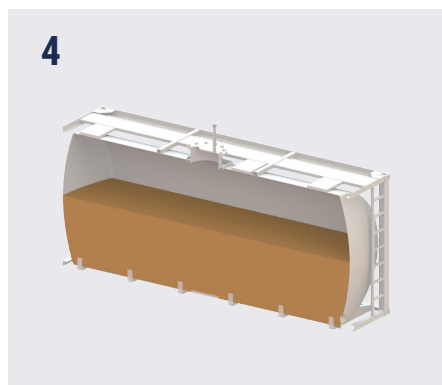
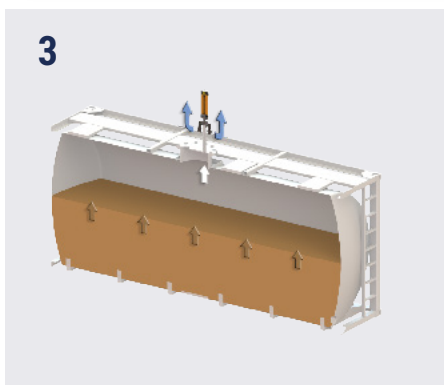
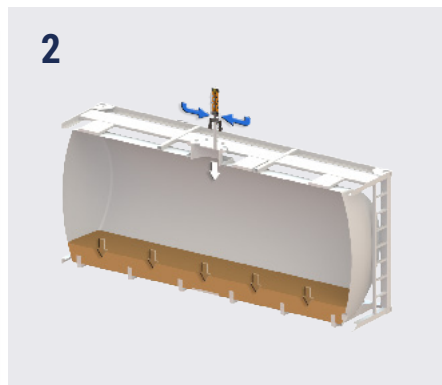
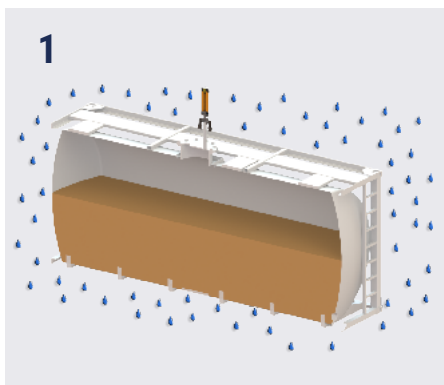

HOW ADSORBERS WORK ON STORAGE TANKS

1 The adsorber is mounted on the storage tank. The ambient air is enriched with moisture.

2 When medium is taken from the tank, the level decreases and pressure is compensated by incoming air. The adsorber separates moisture up to 2% RH (10% rH on average).

3 When the tank is refilled, the level is rising and pressure is compensated by outgoing dry air.

4 Because the air inside the system always remains dry, no condensation takes place in the storage tank even if the ambient air drops below the dew point.

ADSORBERS FOR USE ON STORAGE TANKS.



VV-DV

Disposable version with valves, with FKM seal, for indoor, outdoor & offshore use



VV-RV

Reusable version with valves and FKM seal, for indoor & outdoor use



MA-RV

Reusable version with valves and FKM / EPDM seal, for indoor & outdoor use according to ATEX



ME-RV

Reusable version with valves and FKM / EPDM seal, for indoor, outdoor & offshore use according to ATEX

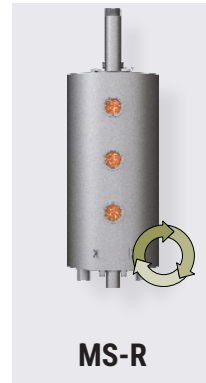

MS-R

Reusable version without valves, with FKM seal, for indoor, outdoor & offshore use according to ATEX



Tank volume	Adsorber size aeration dryer
1-5cbm	3L
6-30cbm	5L
31-60cbm	5XL
61-120cbm	35L
121-...cbm	50L

ADSORBERS FOR **BARRELS & IBC.**



GIEBEL offers a wide range of adsorbers specially designed for **barrels & IBCs**. They are available with and without valves, with FKM or EPDM seals, according to ATEX 2014, for indoor and outdoor use, and as disposable or refillable versions. They are divided into adsorbers for air drying and adsorbers for separation of pollutants.

The adsorber size is determined on the basis of the container volume.

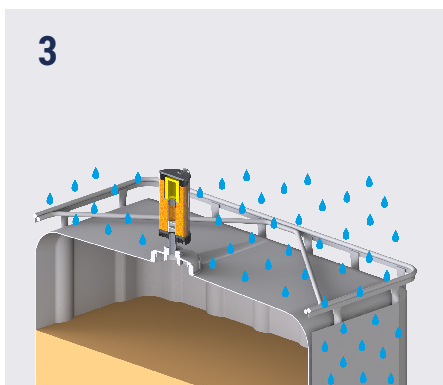
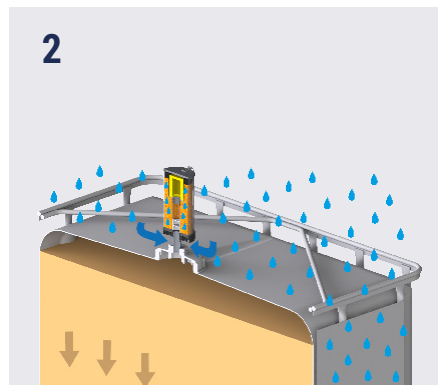
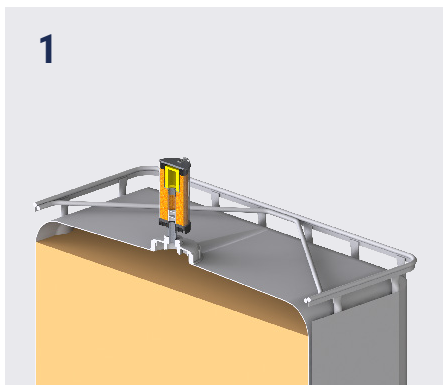

HOW ADSORBERS WORK ON BARRELS & IBC

- 1** The adsorber is mounted on the IBC.
- 2** The ambient air is enriched with moisture. When medium is taken from the IBC, the level decreases and pressure is compensated by incoming air. The adsorber separates moisture up to 2% RH (10% RH on average).
- 3** The moisture remains in the desiccant of the adsorber. No water gets into the container. No loss of quality of the substance.

ADSORBERS FOR USE ON **BARRELS & IBC.**



Disposable version without valves, with FKM seal, for indoor, outdoor & offshore use



Reusable version without valves, with FKM seal, for indoor & outdoor use



Reusable version without valves, with FKM / EPDM seal, for indoor & outdoor use according to ATEX



Container volume	Adsorber size aeration dryer	Adsorber size oil mist separator
60l barrel	1L	1L
200l barrel	2L	2L
1,000l IBC	2L	2L

ADSORBERS FOR **TRANSFORMERS**.

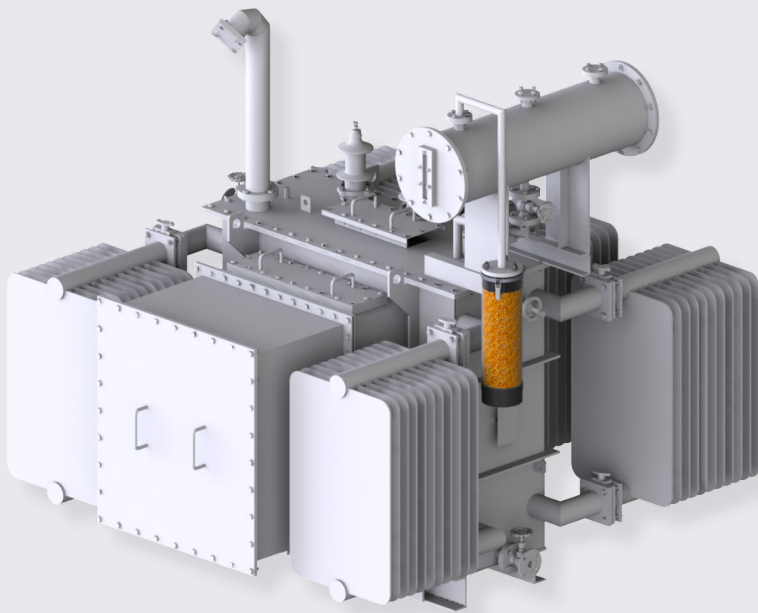

GIEBEL offers a wide range of adsorbers specially designed for **transformers**. They are available for hanging and standing installations, according to ATEX 2014, for indoor, outdoor and offshore use, and as disposable or refillable versions.

The adsorber size is determined on the basis of the transformer power or the oil volume.

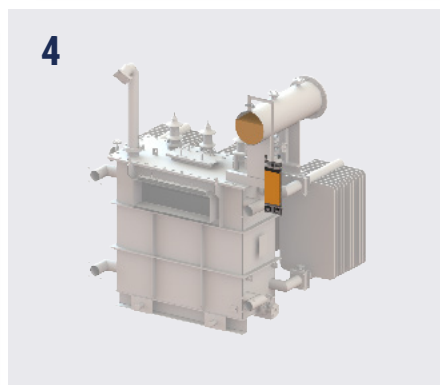
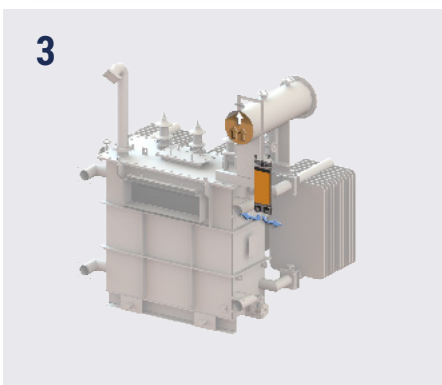
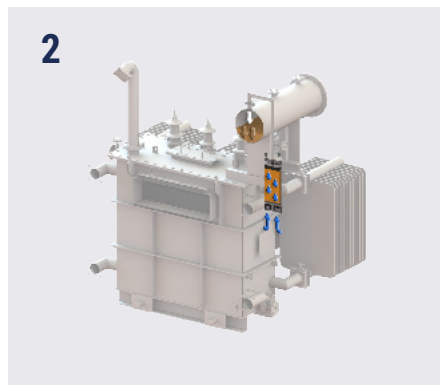

HOW ADSORBERS WORK ON TRANSFORMERS

1 The adsorber is mounted on the transformer. The ambient air is enriched with moisture.

2 If the transformer cools down, the oil level drops and the pressure is equalized by incoming air. The adsorber separates moisture up to 2% RH (10% RH on average).

3 When the transformer warms up, the oil level rises and the pressure is equalized by escaping dry air.

4 Because the air inside the system always remains dry, no condensation takes place in the transformer even if the ambient air drops below the dew point. Water ingress into the insulating oil is prevented.

ADSORBERS FOR USE ON TRANSFORMERS.



TB-DV

Disposable version (Recyclable within GIEBEL Refresh® system) with valves and FKM seal, for indoor & outdoor use



TB-RV

Reusable version with valves and FKM seal, for indoor & outdoor use

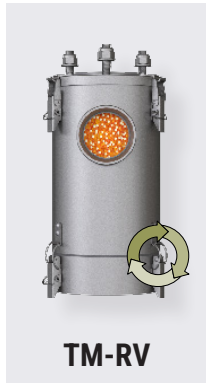

TM-RV

Reusable version with valves and FKM seal, for indoor, outdoor & offshore use according to ATEX

Available with a wide range of connections

DIN42562, DIN42567A, DIN42567B, DIN42567C

Power / tank volume	Adsorber size aeration dryer
0-5MVA (up to approx. 2,500l oil)	3M
6-10MVA (up to approx. 5,000l oil)	3L
11-30MVA (up to approx. 15,000l oil)	5M
31-60MVA (up to approx. 30,000l oil)	5L
61-100MVA (up to approx. 50,000l oil)	5XL

ADSORBERS FOR **MOBILE MACHINERY**.

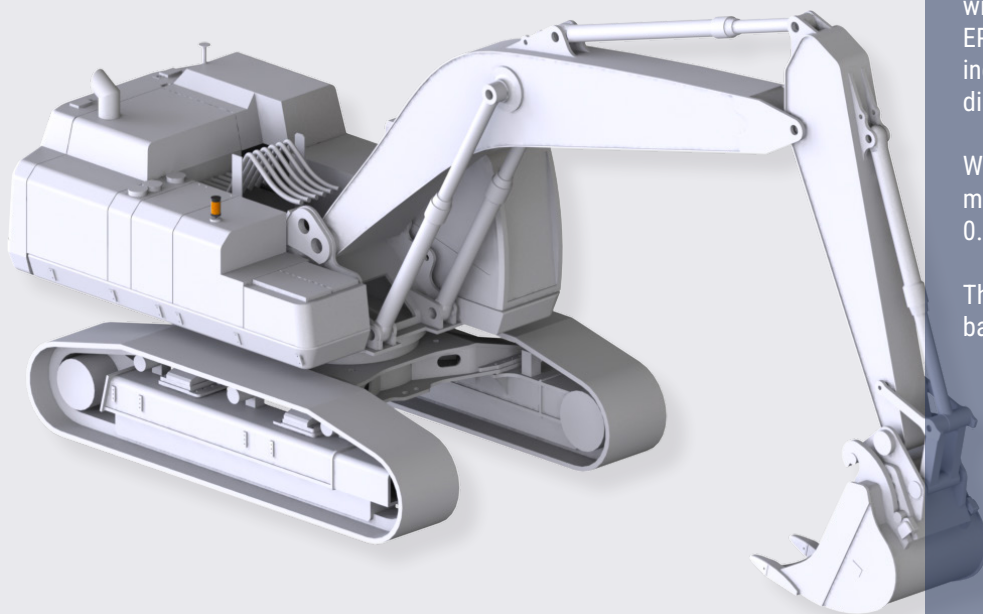

GIEBEL offers adsorbers suitable for **mobile machinery**. They are available with and without valve, with FKM or EPDM seals, according to ATEX 2014, for indoor, outdoor and offshore use and as disposable or refill version.

When mounting adsorbers on mobile machines with tank pressures of 0.3 and 0.5bar, a valve adapter is also installed.

The adsorber size is determined on the basis of the tank volume.

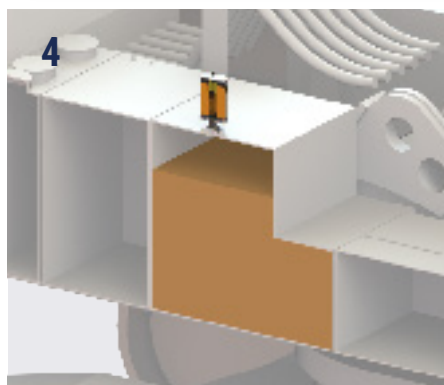
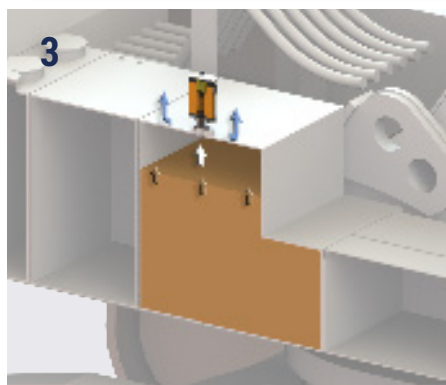
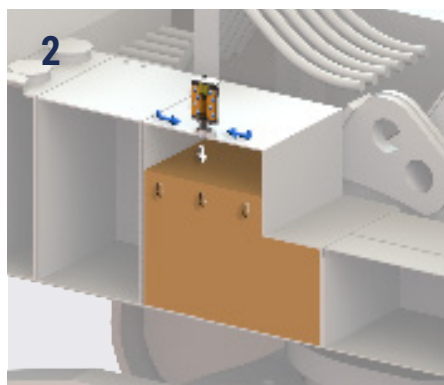
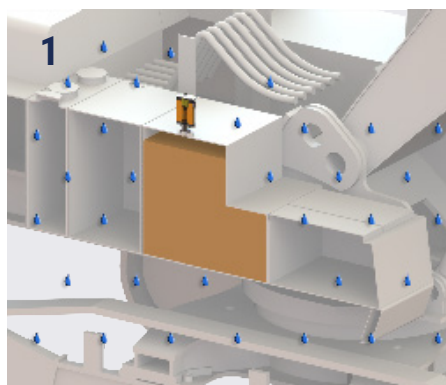

HOW ADSORBERS WORK ON MOBILE MACHINERY

1 The adsorber is mounted on the hydraulic tank of a mobile machine. The ambient air is enriched with moisture.

2 Hydraulic oil is withdrawn from the tank, the oil level drops and the pressure is equalized by incoming air. The adsorber separates moisture up to 2% RH (on average 10% RH).

3 When the hydraulic oil is pumped back into the tank, the oil level rises and the pressure is equalized by the escaping dry air.

4 Since the air inside the system always remains dry, no condensation takes place in the hydraulic tank, even if the ambient air falls below the dew point.

ADSORBERS FOR USE ON **MOBILE MACHINERY**.



Disposable version without valves, with FKM seal, for indoor, outdoor & offshore use



Disposable version with valves, with FKM seal, for indoor, outdoor & offshore use



Reusable version without valves, with FKM seal, for indoor & outdoor use



Reusable version with valves and FKM seal, for indoor & outdoor use



Reusable version with valves and FKM / EPDM seal, for indoor & outdoor use according to ATEX



Reusable version with valves and FKM / EPDM seal, for indoor, outdoor & offshore use according to ATEX



Tank volume	Adsorber size aeration dryer
0 -50l	2L
51-100l	3M
101-400l	5M
401-800l	5XL

ADSORBERS FOR PIPELINES.



GIEBEL offers adsorbers that are specially designed for installation in **pipelines** to separate moisture or even pollutants from a system. For this purpose, the inline adsorbers can be filled with GIEBEL Xdry® (standard), different silica gels, molecular sieves or activated carbon.

The inline adsorbers are designed for different volume flows and are also available in variants that can be operated in explosion protection zones according to ATEX or in high-pressure lines.

The adsorber size is determined on the basis of the volume flow.

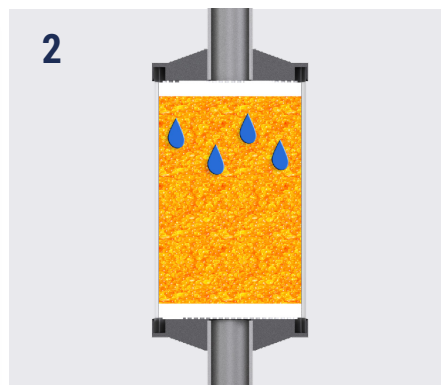

HOW ADSORBERS WORK IN PIPELINES

1 The adsorber is installed vertically or horizontally in a pipeline.

2 Process air flows through the adsorber. Silica gels and molecular sieves absorb moisture contained in the process air. Molecular sieves are also capable of adsorbing other gases. Activated carbon is used when oil mist or other pollutants are to be filtered out.

ADSORBERS FOR USE IN PIPELINES.



VL-D

Disposable inline adsorber with integrated filter



VL-R

Reusable inline adsorber with integrated filter & FKM seals



VM-R

Reusable inline adsorber with integrated filter & FKM seals for use in harsh environments, according to ATEX



Available with a wide range of connections

Tank volume	Adsorber size aeration dryer
0 -50l	2L
51-100l	3M
101-400l	5M
401-800l	5XL

GIEBEL XDRY®.

The strenghts of silica gel & molecular sieve combined

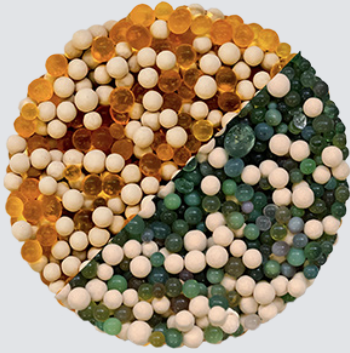

The perfect mixture

GIEBEL Xdry® makes use of the high water absorption capacity and the high-contrast color indicator of silica gel as well as the strong binding energy of molecular sieve to polar substances.

The advantages compared to adsorbents filled purely with silica gel: Giebel Xdry®

can be used at higher temperatures and lower humidity levels, dries the air drawn in significantly more and thus ensures less moisture in the system.

To ensure that our adsorbents provide the best possible drying performance, GIEBEL Xdry® consists of orange-green silica gel and a molecular sieve with an X structure and Na⁺ cations with an effective pore size of 10Å.

GIEBEL Xdry® compared to silica gel

With a maximum water absorption of 35% at 100% RH and 20°C in the climate chamber, GIEBEL Xdry® initially appears to be at a disadvantage compared to pure silica gel with a water absorption of 40%. However, since in practice adsorbents are

already fully loaded and discolored green at a water absorption of approx. 33% - i.e. the cartridge (disposable adsorbent) or the desiccant (reusable adsorbent) needs to be replaced - the slightly lower water absorption of the mixture does not come into play.

The advantages of the GIEBEL Xdry® mixture are particularly evident in its drying

performance. Up to a load of 25%, more water remains in the adsorbent, i.e. less water enters the system. Towards the end of the product life cycle, at a loading between 25% and 35%, both fillings behave more or less the same.

The higher isotherm of GIEBEL Xdry® at lower humidity levels additionally allows use in dry environments from 30% RH.

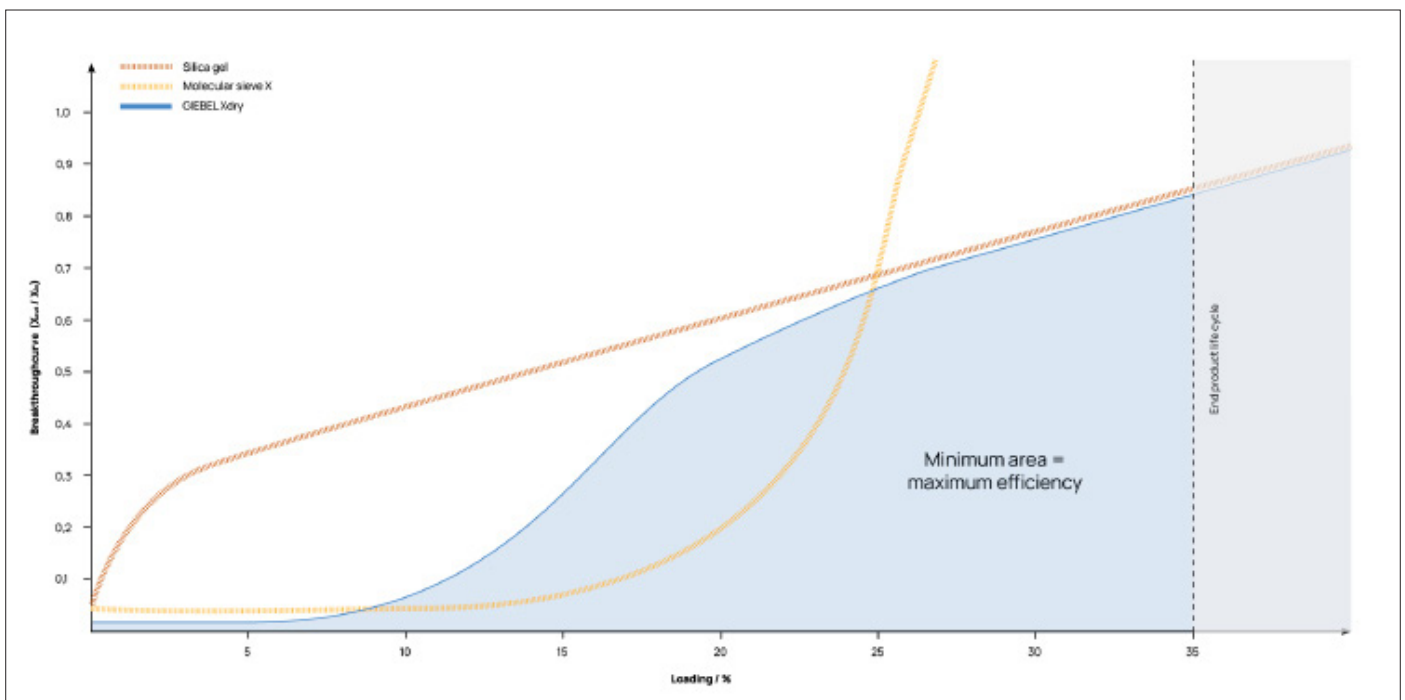

Graphic 1: Residual humidity after loading

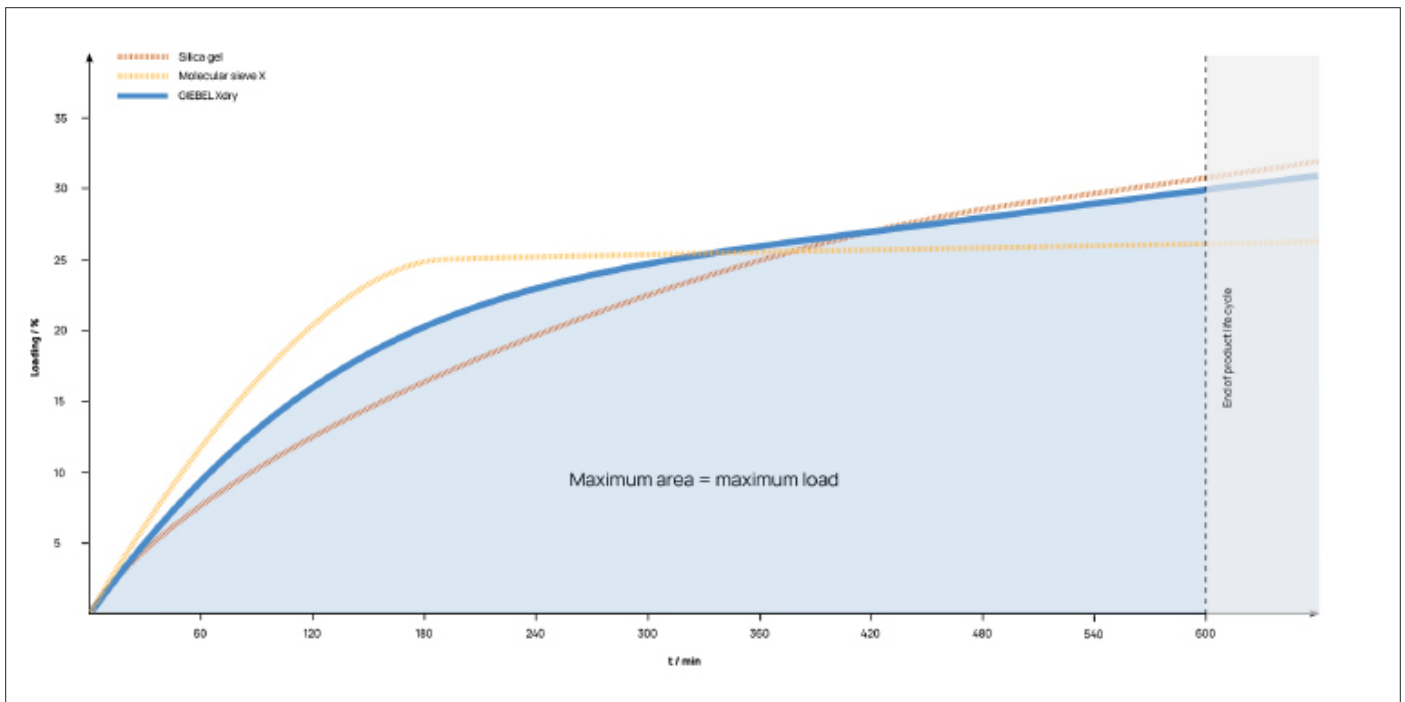

Graphic 2: Loading process

When do I replace an adsorber filled with GIEBEL Xdry®?

The silica gel grains contained in the GIEBEL Xdry® change color to green to indicate that the adsorber or desiccant filling needs to be replaced.

At which temperatures can GIEBEL Xdry® be used?

Adsorbers filled with GIEBEL Xdry® can also be used at temperatures above 80°C. Although the water absorption of the contained silica gel is limited at these high temperatures, the molecular sieve has a

constant water absorption up to approx. 250°C.

How can GIEBEL Xdry® be regenerated?

Due to the different regeneration temperatures of the silica gel and molecular sieve contained in GIEBEL Xdry®, regeneration of the desiccant is not recommended. If silica gel is heated to over 120°C, the color indicator it contains burns out and turns brown. Temperatures below 250°C, on the other hand, have no significant effect on the regeneration of the molecular sieve. The bed of our adsorbers filled with GIEBEL Xdry® is therefore replaced after complete loading. We offer refill packs in

various sizes for this purpose.

Is GIEBEL Xdry® harmful to health?

The components silica gel orange and molecular sieve are classified as non-hazardous substances according to the law of the European Union (Regulation EC No. 1272/2008). They are not subject to mandatory labeling according to the EC Directive (67/548/EEC or 1999/45/EC).

GIEBEL Xdry® is thus also classified as a substance that is not hazardous to health or the environment.

FURTHER INFORMATION ON GIEBEL XDRY® AND ITS BENEFITS CAN BE FOUND ON OUR WEBSITE
WWW.GIEBEL-ADSORBER.COM

GIEBEL SENSE®

Monitoring the loading condition.



GIEBEL Sense® always keeps an eye on the loading status of an adsorber

GIEBEL Sense® is a sensor attached to an adsorber by means of a carrier plate, which detects the loading status of the GIEBEL Xdry® charge and transmits it analog or via Modbus RTU. This allows

you to reorder an adsorber in time, to plan maintenance intervals in a targeted manner and to avoid downtimes at your plants. Signals are output via 4 fixed switching outputs at loading states of 0%, 50%, 75% and 100%.



How it works

The desiccant fill reduces the relative humidity inside the adsorber. The more moisture the packing has already absorbed, the less water it can remove from the air flowing through it. The %RH value of the air surrounding the desiccant is therefore directly related to the loading condition of the adsorber. Thus, the sensor can "measure" the loading condition.

Technical data

	Modbus RTU	Analog
Temperature	-40°C up to +70°C	-40°C up to +70°C
Housing	Polyamide (PA)	Polyamide (PA)
Size	60 x 74 x 33mm	60 x 74 x 33mm
Weight	200g	200g
Input variable	Humidity 0-100% RH	Humidity 0-100% RH
Operating voltage	24V DC	24V DC
Protection class	IP 67	IP 67
Output	RS485 A/B	4-20ma analog signal

Easy installation

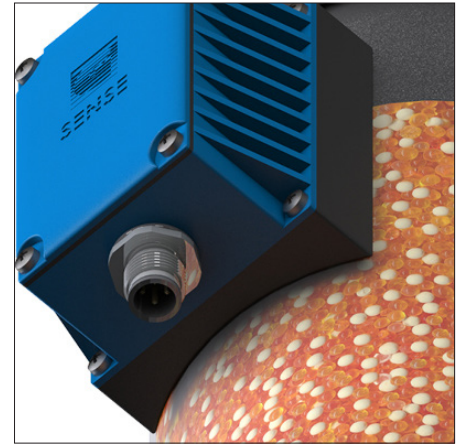
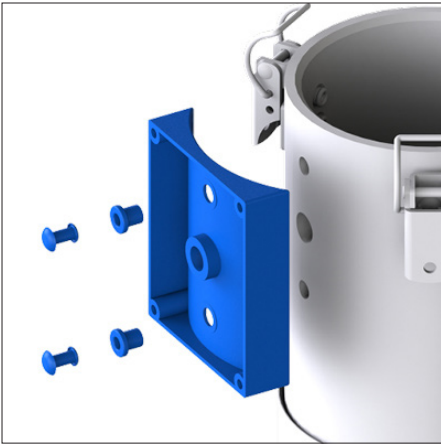

To attach the GIEBEL Sense® to an adsorber, the adsorber is pre-drilled according to the drilling template and fitted with a support plate suitable for the adsorber size (available for the 2, 3 and 5 series).

A PTFE membrane sticker is placed on the inside of the tube on the hole in the center.

The sensor is plugged on and screwed tight. In this way, it can be easily transferred to other adsorbers provided with a carrier plate.

Module plug pinout

	Modbus RTU	Analog
Plug	M12 a-coding, 4-pin	M12 a-coding, 4-pin
Pin 1	+24 V DC (brown)	+24 V DC (brown)
Pin 2	RS485 A (white)	4-20ma (white)
Pin 3	GND (blue)	GND (blue)
Pin 4	RS485 B (black)	- none - (black)

FURTHER INFORMATION ON GIEBEL SENSE®
CAN BE FOUND ON OUR WEBSITE
WWW.GIEBEL-ADSORBER.COM

GIEBEL REFRESH®.

Improve the ecological footprint

Reconditioned & just as good as new

Aeration dryers extend the life of your plant, ensure the quality and longevity of operating oils and eliminate the need to maintain constant room temperatures to prevent condensation – we've also designed them to meet our own standards for sustainability and longevity.

How? By developing refillable adsorbers that require replacement only of those components that have reached the end of their product life cycle. All other components remain in service. With spare parts and fillings, you can replace inner workings yourself - or you can use the GIEBEL Refresh® system to return used adsorbers. We recondition them and put them back into circulation.



1 Return your loaded GIEBEL Adsorber® when it's completely saturated (colored green).



2 Receive a credit on your next order.



3 Operate your plants more cost-effectively and improve your ecological footprint on top of that – because the durable components of your returned adsorbers are used again.

TO REGISTER FOR THE GIEBEL REFRESH® SYSTEM
VISIT OUR WEBSITE
WWW.GIEBEL-ADSORBER.COM

GIEBEL DEVELOPMENT & PRODUCTION.

Under one roof

Driven by the idea of making hygroscopic materials usable over a longer period of time by protecting them from contact with moisture, we develop and produce our GIEBEL Adsorbers® for the global market at our site in Bretzfeld (Germany).

We use recent CAD software to create 3D models and prototypes and manufacture in our two in-house production halls.

We are also researching desiccant mixtures such as our GIEBEL Xdry® and experimenting with other drying processes in order to constantly improve the efficiency of our products.

The foundation of the value chain is based on quality and sustainability. GIEBEL stands for quality made in Germany - we confirm this with our quality manage-

ment system according to DIN EN ISO 9001:2015. And with our participation in the global GS1 system, we also create optimal conditions for smooth data and goods traffic across companies, countries and industries.

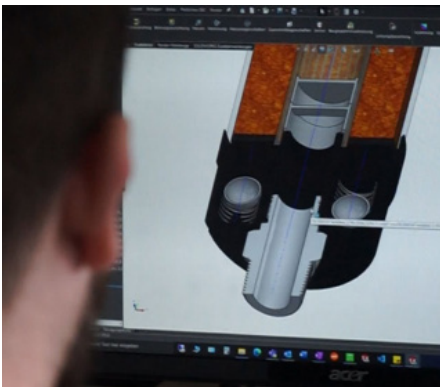

GIEBEL WORLDWIDE.



INTERNATIONALLY ACTIVE - WITH STRONG ROOTS IN GERMANY

From our headquarter, our adsorbers find their way all over the world. We are supported by strong sales partners worldwide.

This network enables us not only to distribute our products worldwide, but also to provide customer advice locally and in the local language.



WOULD YOU LIKE TO BECOME A SALES PARTNER TOO?

We believe in our product and our partners. Let's discuss how we can work together to make Adsorber strong in your region.

Your contact person:

